



# **WEB-BASED CONTROL OF INDUSTRY APPLIANCES USING RASPBERRY PI**

<sup>1</sup>Abinath.T.R, <sup>2</sup>Sudhakar.V, <sup>3</sup>Indhumathi.G, <sup>4</sup>Sathish.P, <sup>5</sup>S.Rajeshwari

<sup>1,2,3,4</sup> Final Year Electrical and Electronics Engineering, Info Institute of Engineering

<sup>5</sup> Associate Professor, Info Institute of Engineering, Coimbatore

<sup>1</sup> [abinathtr@gmail.com](mailto:abinathtr@gmail.com) , <sup>2</sup> [sudhakar93@live.com](mailto:sudhakar93@live.com)

*Abstract - Industrial automation platforms are experiencing a paradigm shift. New technologies are making their way in the area, including embedded real-time systems, standard local area networks like Ethernet, Wi-Fi and ZigBee, IP-based communication protocols and Web Services. The aim of this work is to develop an embedded system directed at automating appliances in an industry via Ethernet. The system employs server/client architecture; switching commands for the appliances which are connected to the client can be received and displayed at either end. The remote host processes the commands received and translates them into actions of switching particular appliances ON, OFF and speed control of machines. The Raspberry Pi is a low cost, credit-card sized computer that plugs into a computer monitor or TV and uses a standard keyboard and mouse which acts a remote host in this system. It is a capable little device that enables people of all ages to explore computing, and to learn how to program in languages like Scratch and Python. A website is hosted which communicates with the Raspberry Pi server to alter the values of the machine. As the parameters are changed in the webpage, the result is reflected in the output of the machine. A live streaming feature is added to the system to ensure the safety and security of the machine. The machine parameter's can be monitored as well as controlled from the website itself. The site can be secured by using a login which prevents unnecessary intrusions.*

*Keywords: Ethernet, Wi-Fi, Raspberry Pi*

## **I. INTRODUCTION**

Until more recently, induction motors (IMs) have performed the main part of many speed control systems and found usage in several industrial applications because they demonstrate trouble-free operation for long periods of time. The advances in microprocessors and power electronics have permitted the implementation of modern techniques for induction machines. The proposed model will have a website by which the control of the industrial appliances can be done. The control can be performed from any corner of the world with the help of a hosted website which is used in interchanging the values between the appliances and the site. The industry will have different apparatus which can also be controlled using this website. The speed and the operating voltage of the

motor can be measured. The measuring of the speed is done with the help of proximity sensor and measuring of the voltage is done with the help of voltage divider. Thus measured quantity will be given to a controller and will convert it to digital and will send to raspberry pi. The speed value set in the website will be set as the reference to the controller and it will give the PWM pulse as output to the driver circuit. Based on the generated pulse the speed of the motor can be controlled. The other appliances in the industry can also be switched on and off from the website. A live video streaming facility is added to monitor the operation of the Induction Motor from the website.

## II. OVERVIEW OF PROJECT

In this paper, an experimental setup is implemented with real instruments. An arduino controller is used along with the raspberry pi to achieve the desired result. A Web-based system is developed using the Smart Access feature of the Raspberry pi. The equipment used in experimental setup is shown in Fig.1

The components of the experimental setup are:

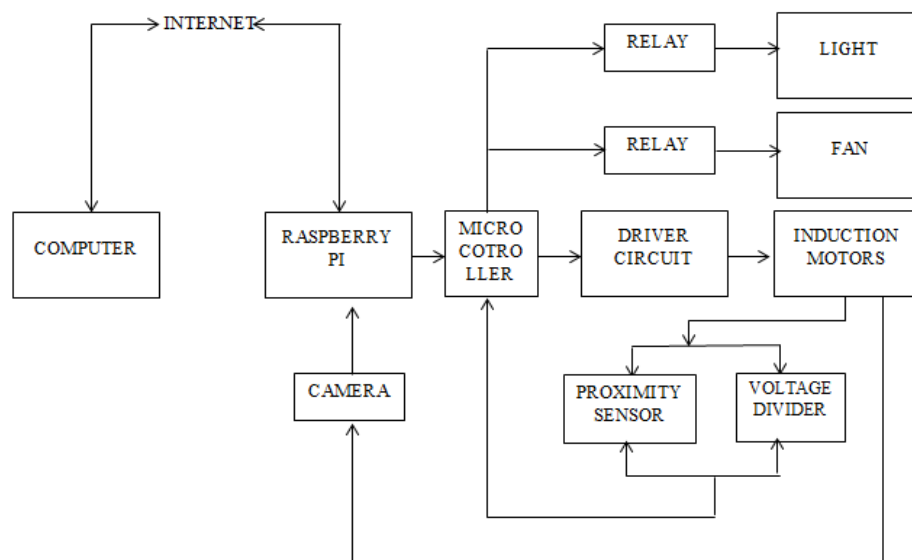

Fig 1. Block Diagram

1. Computer is used to view the website.
2. Raspberry pi is a credit card size computer that is fixed in industry to have a network.
3. Micro controller help in ADC/DAC conversion and to generate pulse signals.
4. Relay acts as a switch in turning OFF and ON other appliances.
5. Driver circuit is used to control the input to the Motor.
6. Voltage divider is used for the purpose of measuring the voltage.
7. Proximity sensor along with a timer IC is used to measure the speed of the motor.

8. Camera is used for the purpose of live streaming.

### III. SIMULATION

The simulation was done using MATLAB

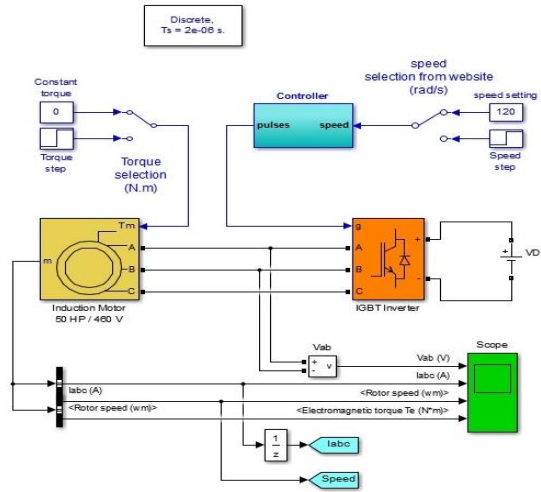

Fig 2. Simulation block

The block have following components

1. Controller is used to generate the Gate signal to the IGBT inverter based on the value set in the website.
2. IGBT inverter acts as a PWM generator and supplies the input voltage the motor.
3. Induction motor runs with the voltage obtained from the inverter.
4. Torque selection is used to select the torque value to the induction motor.
5. Scope is used to display the input voltage, speed of the rotor and the current value along with the torque.

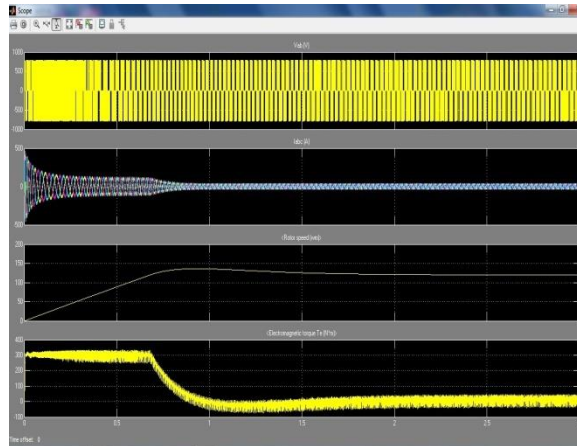

Fig 3. Simulated output

1. The first graph shows the input PWM pulse given to IGBT inverter.
2. Second graph shows the input current to the IM.

3. Third graph shows the speed change of the IM
4. Fourth graph shows the torque of the IM.

#### IV. WEB-BASED CONTROL

The design of the website was done using php Designe. The web page has a authentication page as the homepage. shown as in fig 4.

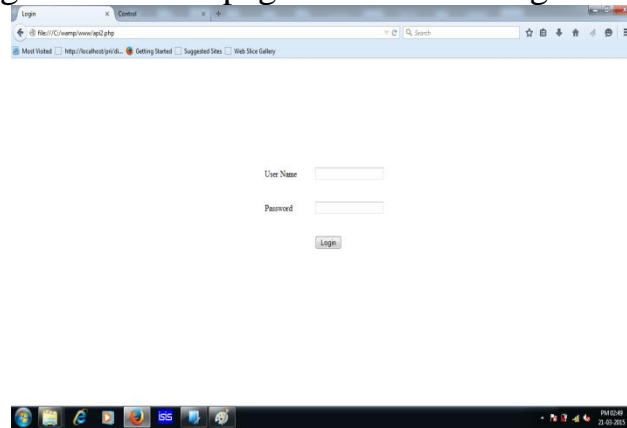

Fig 4. Login page

Authentication of the page is used in order to avoid unauthorised accessing of the website. After logging in it will be taken to the control page as shown in fig 5.

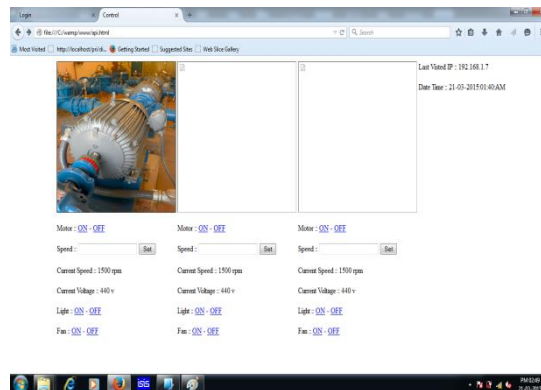

Fig 5 Control page

The control page is used in controlling the industry appliances and for viewing the video stream from the camera. The IP address along with date and time of the last visited system will be displayed on the site. When the required speed is entered and the set button is clicked the signal is sent to the controller and the speed of the motor changes.

## V. CONCLUSION

In this paper, a Web-based remote access and monitoring of industrial appliances is presented. For this purpose, an embedded based structure was developed to control the system. For monitoring and supervising purpose a camera was installed in the system.

The main advantages are:

1. The industry can be controlled and monitor remotely from any part of the world.

Username and password protection was added to permit access to the web page for only authorized users. Every access is recorded and the IP address along with date and time is stored.

Because of the advantages mentioned above, the system is not only user-friendly it is also reliable, flexible and cost effective.

## REFERENCES

[1] Zafer Aydogmus and Omur Aydogmus, "A Web-Based Remote Access Laboratory Using SCADA" *IEEE TRANSACTIONS ON EDUCATION*, VOL. 52, NO. 1, FEBRUARY 2009

[2] Yih-Neng Lin and Chern-Lin Chen, *Member, IEEE* "Automatic IM Parameter Measurement Under Sensorless Field-Oriented Control" *IEEE TRANSACTIONS ON INDUSTRIAL ELECTRONICS*, VOL. 46, NO. 1, FEBRUARY 1999

[3] Theocharis K. Boukas, *Member, IEEE*, and Thomas G. Habetler, *Fellow, IEEE* "High-Performance Induction Motor Speed Control Using Exact Feedback Linearization With State and State Derivative Feedback"

[4] Tamir Hegazy, *Senior Member*, Mohamed Hefeeda, *Senior Member* "Industrial Automation as a Cloud Service", *IEEE TRANSACTIONS ON PARALLEL AND DISTRIBUTED SYSTEMS*,

[5] Mohamed M. M. Negm, *Senior Member, IEEE*, Jamil M. Bakhawain, and M. H. Shwehdi, *Senior Member, IEEE* "Speed Control of a Three-Phase Induction Motor Based on Robust Optimal Preview Control Theory" *IEEE TRANSACTIONS ON ENERGY CONVERSION*, VOL. 21, NO. 1, MARCH 2006