



**RESEARCH ARTICLE**

# **LABVIEW Based Module For Bio Signals Monitoring**

Sabeetha Begum.M  
PG Scholar, ECE, PSNACET,  
Dindigul, Tamil Nadu, India.  
[msam.sabeetha@gmail.com](mailto:msam.sabeetha@gmail.com)

Kumarnath.J  
Assistant Prof., ECE, PSNACET,  
Dindigul, Tamil Nadu, India.  
[jkumarnath@gmail.com](mailto:jkumarnath@gmail.com)

---

*Abstract— This project proposes a miniaturized module of the FPGA interfacing system with Zigbee transceiver. This offer a powerful system, which will monitor the human heartbeat and EEG signals. In existing system NIOS II embedded and MATLAB are used, instead of that we use LABVIEW platform for simulate the response signal. It will reduce the hardware complexity of the system. The main aim of using software in monitoring system is data visualization and analysis. On the system, analog and digital circuits are integrated, whereas field-programmable gate array hardware and LABVIEW are co-operated. FPGA has been programmed with software module. In this monitoring, the unusual reaction in the system will send the information to the doctor via the recorded voice. In this we use Zigbee transceiver for efficient treatment to the patient. The analog section is composed of amplifier, analog to digital converter, signal conditioning unit. Signal capture and amplification are realized by an analog circuit, whereas signal process, signal analysis, and man-machine interface control are implemented on a field programmable gate array digital platform. In addition to this, to pursue high performance and good expandability, LABVIEW is employed and system tasks are partitioned to hardware and software. It is mainly used in the application of brain death detection for coma patient.*

*Keywords— Field Programmable Gate Array (FPGA); Laboratory Virtual Instrumentation Engineering Workbench (LABVIEW); Electroencephalogram (EEG); Brain Death Detection; Heart Rate Variability (HRV); Zigbee*

---

## I. INTRODUCTION

Living organisms are made up of many component systems same as the human body includes several systems. Each system is made up of several subsystems that carry many physiological processes. Cardiac system is rhythmic pumping of blood throughout the body to facilitate the delivery of nutrients, and pumping blood throughout the pulmonary system for oxygenation of the blood itself. Diseases or defects in a biological system cause in its normal physiological processes, leading to pathological process that affect the performance, health, and wellbeing of the system. A pathological process is naturally associated with signals that are different in some respects from the corresponding normal signals. There is a need for good understanding of a system of interest to observe the corresponding signals and

assess the state of the system. A pathological process is indicated to represent its effects on the system and its output.

The Biomedical Workbench in LabVIEW Biomedical Toolkit provides applications for biosignal and biomedical image analysis. These applications make possible you to apply biomedical solution using National Instruments software, such as LabVIEW, with National Instruments hardware. You can use these applications to screen and play biosignals, simulate and generate biosignals, evaluate biosignals, and view biomedical imagery [3]. You can acquire real world and real-time biomedical data by using biomedical sensors and National Instruments hardware. You also can import biomedical information from files, such as files from the Physio bank MIT-BIH database, to the applications in this kit for analysis. You can use the applications in Biomedical Workbench to analyse heart rate variability (HRV) and to extract features from Electroencephalogram (EEG) signals. You also can use National Instruments hardware and the applications in this kit to generate standard analog, biomedical signals to validate and test your biomedical instruments. Brain death is a transient stage of life when organs could be used to donate for other alive patients with organ failure [2].

## II. FUNCTION DESCRIPTION

On the system, analog and digital circuits are integrated, whereas FPGA hardware and LABVIEW software are co-operated. In proposed system, we can observe the HEART RATE and EEG monitoring. Signal capture and amplification are realized by an analog circuit. Signal analysis and man-machine interface control are implemented on a FPGA platform.

LabVIEW is graphical programming environment. Programs in IDE are called Virtual Instruments (VIs), consists of a Block Diagram (BD) and a Front Panel (FP). A BD provides a graphical code development environment whereas a FP allows the user to interact with a VI. It provides an efficient and easy-to-use environment for code development especially when the user needs to interact with the program and visualize the results.

In this monitoring system, we use two bio signals as input signals. The first one is brain wave, which is capture by using EEG sensor. The second one is heartbeat, which is count by that specified sensor. These two signals are processed and feed to the FPGA kit. Thus the FPGA module is connected to zigbee for transmit the data to the receiver.

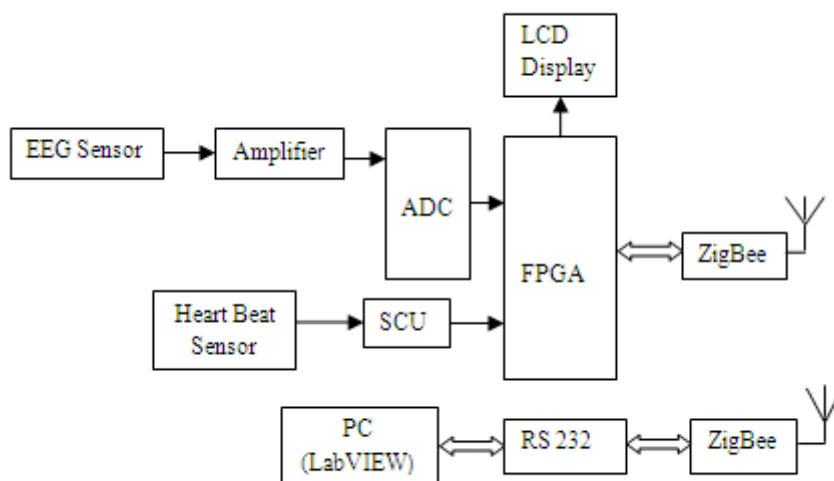

Fig. 1. Function description of monitoring system.

A. *Electroencephalogram (EEG)*

EEG including brain waves or oscillations categorized into different frequency bands can be seen as a common activity of a large population of neurons in the neocortex. Brainwaves are measured in two ways. The first is frequency, or speed of electrical pulses. Frequency is measured in cycles per second (cps or HZ), ranging from .5cps to 38cps. The second measurement is amplitude, or strong of the brainwave. There are four categories of brainwaves such as Beta, Alpha, Theta, and Delta. When we are accessing our self we are able to use a combination of all four brainwaves.

Theta activity occurs in children and sleeping adults and delta activity in infants and sleeping adults. Alpha activity is best observed in occipital regions and beta activity can be seen if alpha rhythmic activity disappears mainly in parietal and frontal areas in adults. When we fall asleep our brain shift works. Just as we unconsciously adjust our brainwaves in sleep, we can learn to consciously adjust our brainwaves while we are awake.

TABLE I. TYPICAL EEG TRACES IN DIFFERENT BANDS

Beta	13-30Hz	
Alpha	8-13 Hz	
Theta	4-8 Hz	
Delta	0.5-4 Hz	

TABLE II. FREQUENCY RANGE OF THE DIFFERENT EEG BANDS

EEG band		Frequency range [Hz]
Delta		0.5-4
Theta		4-8
Alpha	Lower alpha	8-10
	Upper alpha	10-13
Beta		13-30
Gamma		>30

All four rates occur at once, yet at varying amplitudes. A good analogy would be to relate each brainwave state to a string on a violin. All four strings make notes, yet one or more strings can dominate the overall sound at a greater volume. The design of the Brain System lends itself to driving multiple rates at once, allowing you to entrain to a broad range of brainwave rates within each level.

Amplitudes of the ongoing EEG are in the range of 50 – 100 $\mu$ V. The amplitudes depend on the type of EEG derivation (bipolar derivation yields smaller amplitudes compared to mono polar derivations) and on the location of electrode placement. The interesting frequency ranges are between 0 – 40 Hz. Sometimes components up to 80 Hz are investigated. EEG is used to appear at your brain activity. It can help to detect seizures. It can be used to monitor the brain diseases such as Alzheimer's disease, Confusion, Head injuries, Infections and Tumors.

### B. Amplifier

An electronic amplifier is an electrical device that increases the power of a signal. It does this by increases the power of a signal. It does this by taking energy from a power supply and controlling the output to match the input signal shape but with large amplitude. In this sense, an amplifier may be considered as modulating the output of the power supply. Here we use inverting amplifier. We can change the gain by adjusting the value of feedback resistance value.

As the open loop BC gain of an operational amplifier is extremely high we can afford to lose some of this gain by connecting a suitable resistor across the amplifier from the output terminal back to the inverting input terminal to both reduced and control the overall gain of the amplifier. This then produces an effect commonly known as Negative Feedback, and thus produces a stable Operational system. A common solution to help become stable the output devices is to include some emitter resistors, typically an ohm or so. Calculating the values of the circuit's resistors and capacitors is done based on the components employed and the intended use of the amp.

### C. Heart Rate

A heart rate monitor consists of two parts as a transmitter and a receiver. As the heart beats, an electrical signal is transmitted through the heart muscle in order for it to contract. This electrical activity can be detected through the skin. The transmitter part of the heart rate monitor is placed on the skin around the area that the heart is beating, and picks up this signal. The transmitter then sends an electromagnetic signal containing heart rate data to the receiver which displays the heart rate. The heart pumps blood through the body in pulses. The muscles of the heart contract and relax, pushing oxygenated blood through the body and

allowing deoxygenated blood to return to the heart, to go on to the lungs. This does not mean that the body is not constantly filled with blood.

In reality, it simply means that the arrival of fresh oxygenated blood through the body occurs in pulses, which are timed to the heart's contraction, or heartbeat. It is a term used to express the frequency of the cardiac cycle. A heart rate monitor is a personal monitoring device which allows one to measure his or her heart rate in real time or record the heart rate for later study. The HRV procedure is a powerful tool to assess the ANS in comatose patients [1]. It is considered one of the four important signs. Regularly it is calculated as the number of contractions (heart beats) of the heart in one minute and expressed as "beats per minute" (bpm).

The Pulse rate (which in most people is identical to the heart rate) can be measured at any point on the body where an artery is close to the surface. Such places are wrist (radial artery), neck (carotid artery), elbow (brachial artery), and groin (femoral artery). The pulse can also be felt directly over the heart. Producing an electrocardiogram, or ECG (also abbreviated EKG), is one of the most precise methods of heart rate measurement. Continuous electrocardiographic monitoring of the heart is regularly done in many clinical settings, especially in critical care medicine.

#### *D. Signal Conditioning Unit*

Signal Conditioning means manipulating an analog signal in such a way that it meets the requirements of the next stage for further processing. This unit accepts input signals from the analog sensors and gives a conditioned output of 0-5V DC corresponding to the entire range of each parameter. Outputs for signal conditioning equipment can be voltage, current, frequency, timer or counter, relay, resistance or potentiometer, and other specialized outputs. It includes amplification, filtering, converting, range matching, isolation and any other processes required to make sensor output suitable for processing after conditioning.

#### *E. LCD Display*

Liquid crystal displays have materials which combine the properties of both liquids and crystals. Rather than having a melting point, they have a temperature range contained by which the molecules are almost as mobile as they would be in a liquid, but are grouped together in an ordered form related to a crystal. LCD consists of two glass panels, with the liquid crystal material sandwiched between them. The inner surface of the glass plates are covered with opaque electrodes which define the character, symbols or patterns to be displayed. Polymeric layers are present in between the electrodes and the liquid crystal, which makes the liquid crystal molecules to keep a defined direction angle. The LCD does not generate light and so light is needed to read the display. By using backlighting, reading is possible in the dark. The LCD's have durability and a wide operating temperature range.

Changing the display size or the layout size is quite simple which makes the LCD's more customer friendly. The LCDs used exclusively in watches, calculators and measuring instruments are the simple seven-segment displays, having a limited amount of numeric data. The recent advances in technology have resulted in better legibility, more information displaying capability and a wider temperature range. These have resulted in the LCDs being extensively used in telecommunications and entertainment electronics. The LCDs have even

started replacing the cathode ray tubes (CRTs) designed for the display of text and graphics, and also in small TV applications.

#### F. RS232

In telecommunications, RS 232 is a standard for serial binary data interconnection between a *DTE* (Data terminal equipment) and a *DCE* (Data Circuit-terminating Equipment). It is commonly used in computer serial ports.

#### G. FPGA

It is a family of general-purpose logic devices that can be configured by the end user to perform many, different, complex logic functions. It is often used for prototyping logic hardware. An FPGA is similar to a PLD, but whereas PLDs are commonly narrow to hundreds of gates, FPGAs support thousands of gates. They are in particular for prototyping integrated circuit designs. Once the design is set, hardwired chips are produced for faster performance. Semiconductor devices that are based around a matrix of configurable logic blocks (CLBs) connected via programmable interconnects. FPGAs can be reprogrammed to preferred application or functionality requirements after manufacturing. This feature distinguishes FPGAs from Application Specific Integrated Circuits (ASICs), which are custom manufactured for specific design tasks. Although one-time programmable (OTP) FPGAs are available, the dominant types are SRAM based which can be reprogrammed as the design evolves.

#### H. ZIGBEE

ZigBee is a specification for a suite of high level communication protocols using small, low-power digital radios based on an IEEE 802 standard for personal area networks. Applications include wireless light switches, electrical meters with in-home-displays, and other consumer and industrial equipment that require short range wireless transfer of data at relatively low rates. The technology defined by the ZigBee specification is intended to be simpler and less expensive than other WPANs, such as Bluetooth. ZigBee is targeted at radio-frequency (RF) applications that require a low data rate, long battery life, and secure networking. ZigBee has a defined rate of 250 kbps best suited for periodic or intermittent data or a single signal transmission from a sensor or input device. ZigBee operates in the industrial, scientific and medical (ISM) radio bands. Data transmission rates vary from 20 to 250 kilobits/second.

ZigBee coordinator is the most capable device, the coordinator forms the root of the network tree and might bridge to other networks. There is exactly one ZigBee coordinator in each network. It is able to store information about the network, including acting as the Trust Center & repository for security keys. ZigBee router can act as an intermediate router, passing on data from other devices. ZigBee End Device contains just enough functionality to talk to the parent node either the coordinator or a router, it cannot relay data from other devices. This relationship allows the node to be asleep a significant amount of the time thereby giving long battery life. ZigBee has been proved to be a key technology for home automation and sensor networks, but; also extremely valuable in some healthcare applications [4]. This information can then be used by doctors to monitor when intervention might be required.

### III. SOFTWARE DETAILS

#### A. .LabVIEW

LabVIEW programs are called **Virtual Instruments**, or VIs, because their appearance and operation imitate physical instruments, such as oscilloscopes and multi meters. LabVIEW contains a comprehensive set of tools for acquiring analyzing, displaying, and storing data, as well as tools to help you troubleshoot your code. The goal is to design electronic circuitry to accommodate the operation of two biomedical instrumentation devices, away to interface all signals with LabVIEW, and a program to display data from each device in one user-friendly program.

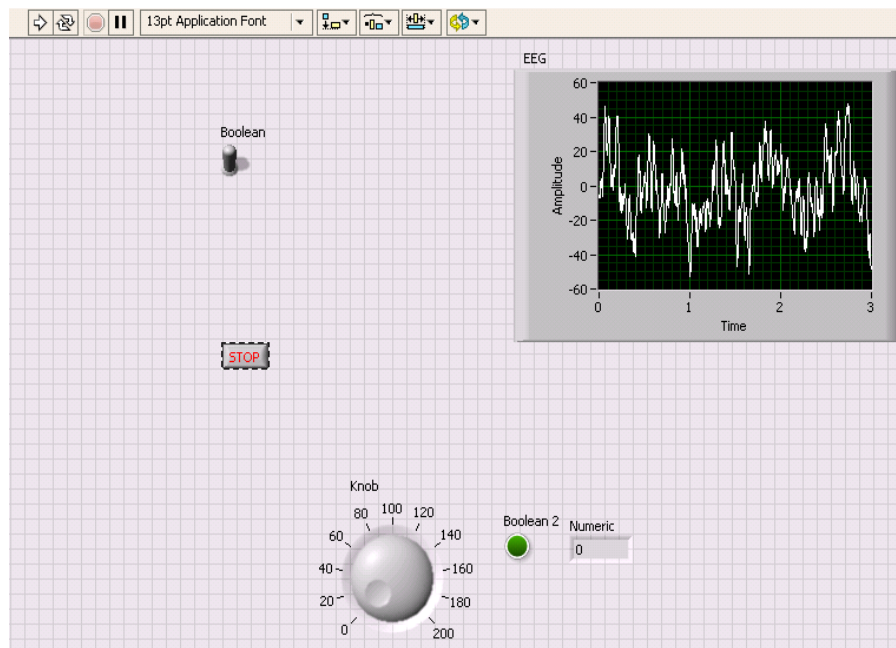

Fig. 2. Front panel of the system

In LabVIEW, we build a user interface, or front panel, with controls and indicators. Controls are knobs, push buttons, dials, and other input devices. Indicators are graphs, LEDs, and other displays. Controls simulate instrument input devices and supply data to the block diagram of the VI (Fig.3). Indicators simulate instrument output devices and display data the block diagram acquires or generates. The block diagram includes wires, front panel icons, functions, possibly subVIs, and other LabVIEW objects. For both applications we use separate Case Structure. It has one or more sub diagrams, or cases, exactly one of which executes when the structure executes. For EEG we use Boolean input knob.

Input signal is received from human body by using sensors. EEG block is extracted from biomedical toolkit. The graphical representation gives the output as waveform. Thus the heart rate measurement uses the knob, limited from range of (60-90) heart rate per minutes. The green light is on when the system is in on state. When the above range is exceeded the light will go off. Simultaneously the number count is displayed. When the abnormality is detected, the system will enable the recorded voice to intimate the doctor.

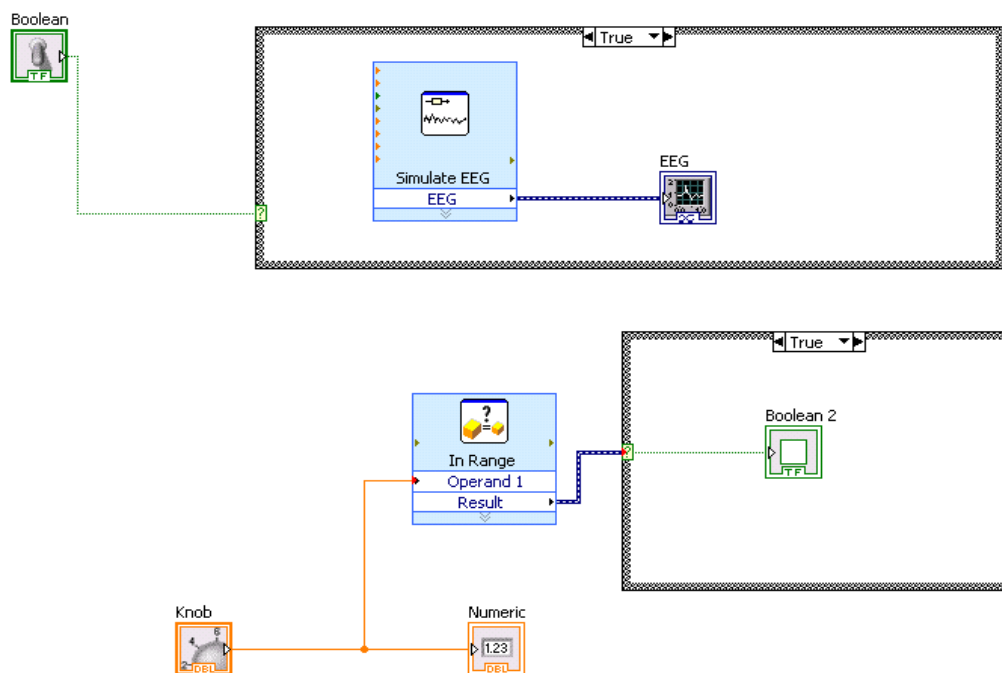

Fig. 3. Block Diagram of the system

#### IV. CONCLUSIONS

Thus a simple setup for sensing bio signals from the human body is implemented. A system Collect the response signal from the human body, process the received signal, analyse information from it, and notify the doctor to analyse the result. The doctor will treat the patient according to the result of the system. Signal capture and amplification are realized by an analog circuit, whereas signal process, signal analysis, and man-machine interface control are implemented on a field programmable gate array digital platform. In addition to this, to pursue high performance and good expandability, LABVIEW is employed and system tasks are partitioned to hardware and software rationally. The design and implementation of Zigbee based wireless bio signals monitoring system using LABVIEW is implemented and simulation is done.

The heart beat and brain signals are sensed and accurate output is displayed. HRV is a minimally invasive, low-cost methodology, suitable for assessing the autonomic nervous system (ANS) in coma. Organs used for transplantation are typically derived from heart-beating brain dead donors. When the brainwaves disappear in EEG display, which will indicate as brain death is happen. The recorded voice intimate as brain death may occur. The alert to doctor will be intimated via enable recorded voice. While the heart rate is below the normal range the green light will be glow, to warn the doctor for short time of organ transplantation. Thus the analysis appeared as an early finding for the identification of brain death.

#### V. FUTURE ENHANCEMENTS

Different transform techniques will be use for improve accuracy. A programme will be implemented on the mobile platform. We will generate ECG waveform by using heartbeat rate. The response of bio signal will be store in SD card for future reference of that particular patient. Data compression techniques are used for reduce storage space. In future different bio signals will be used for analysis. It will be low cost specialist application for coma



patients. Instead of voice signal, we will use alarm. The field of biomedicine will be applicable.

#### REFERENCES

- [1] Qijun Huang, Sheng Chang, Junqi Peng, Xueying Mao, You Zhou, and Hao Wang “An Implementation of SOPC-Based Neural Monitoring System,” *IEEE Trans. Instrum. Meas.*, vol. 61, no. 9, pp. 2469–2475, 2012.
- [2] Ali Reza Vakilian<sup>1</sup>, Farhad Iranmanesh<sup>1</sup>, Ali Esmaeili Nadimi, and Jafar Ahmadi Kahnali, “Heart Rate Variability and QT Dispersion Study in Brain Death Patients and Comatose Patients with Normal Brainstem Function”, *Journal of the College of Physicians and Surgeons Pakistan.*, Vol.21,no.3,pp.130-133,2011.
- [3] Jigar D. Shah, M. S. Panse, “EEG purging using LABVIEW based wavelet analysis”, *National Conference on Computational Instrumentation CSIO Chandigarh, INDIA*, pp.19-20, March ,2010.
- [4] Adriana N. Sirbu Victor-Andrei V.D. Maiorescu Ioan I. Cleju, “A zigbee solution for telemedicine applications”, *Electronics and Telecommunications*, Volume 49, no 3, pp. 35-39, 2008.
- [5] Y. Shang, R. Cheng, L. Dong, S. J. Ryan, S. P. Saha, and G. Yu, “Cerebral monitoring during carotid endarterectomy using near-infrared diffuse optical spectroscopies and electroencephalogram,” *Phys. Med. Biol.*, vol. 56, no. 10, pp. 3015–3032, 2011.
- [6] J. Yelnik, P. Damier, S. Demeret, D. Gervais, E. Bardinnet, B. P. Bejjani, C. Francois, J. L. Houeto, I. Arnulf, D. Dormont, D. Galanaud, B. Pidoux, P. Cornu, and Y. Agid, “Localization of stimulating electrodes in patients with Parkinson disease by using a three-dimensional atlas-magnetic resonance imaging coregistration method,” *J. Neurosurg.*, vol. 99, no. 1, pp. 89–99, 2003.
- [7] S. S. Haghighi, “Monitoring of motor evoked potentials with high intensity repetitive transcranial electrical stimulation during spinal surgery,” *J. Clin. Monit. Comput.*, vol. 17, no. 5, pp. 301–308, 2002.
- [8] Y. L. Lo, Y. F. Dan, Y. E. Tan, A. Teo, S. B. Tan, W. M. Yue, C. M. Guo, and S. Fook-Chong, “Clinical and physiological effects of transcranial electrical stimulation position on motor evoked potentials in scoliosis surgery,” *Scoliosis*, vol. 5, no. 3, 2010. doi:10.1186/1748-7161-5-3.
- [9] S. Sanchez-Solano, A. J. Cabrere, I. Baturone, F. J. Moreno-Velo, and M. Brox, “FPGA implementation of embedded fuzzy controllers for robotic applications,” *IEEE Trans. Ind. Electron.*, vol. 54, no. 4, pp. 1937–1945, Aug. 2007.
- [10] R. Szplet, J. Kalisz, and R. Szmsanowski, “Interpolating time counter with 100ps resolution on a single FPGA device,” *IEEE Trans. Instrum. Meas.*, vol. 49, no. 4, pp. 879–883, Aug. 2000.
- [11] R. Szplet and K. Klepacki, “An FPGA-integrated time-to-digital converter based on two-stage pulse shrinking,” *IEEE Trans. Instrum. Meas.*, vol. 59, no. 6, pp. 1663–1670, Jun. 2010.
- [12] A. Lakshmikanth and M. M. Morcos, “A power quality monitoring system: a case study in DSP-based solutions for power electronics,” *IEEE Trans. Instrum. Meas.*, vol. 50, no. 3, pp. 724–731, Jun. 2001.
- [13] V. Medina, O. Rivera, D. Oviedo, E. Dorrnzoro, and I. Gomez, “Open and flexible embedded system applied to positioning and telecontrol,” *IEEE Trans. Instrum. Meas.*, vol. 60, no. 12, pp. 3816–3823, Dec. 2011.