

## International Journal of Computer Science and Mobile Computing

A Monthly Journal of Computer Science and Information Technology

ISSN 2320-088X



*IJCSMC, Vol. 3, Issue. 5, May 2014, pg.34 – 42*

### **RESEARCH ARTICLE**

# **MONITORING AND SECURITY SYSTEM OF LOCOMOTIVES USING CAN AND PRINCIPLE COMPONENT ANALYSIS**

**<sup>1</sup>Lingaraju M R, <sup>2</sup>Pradyumna Bhat**

<sup>1,2</sup>Department of Electronics and Communication Engineering, NMAM Institute of Technology, Nitte  
Email: [lingarajumr2@gmail.com](mailto:lingarajumr2@gmail.com), [Pradyumnabhat@gmail.com](mailto:Pradyumnabhat@gmail.com)

*Abstract — Controller Area Network (CAN) is a network protocol that allows multiple processors in a system to communicate efficiently with each other. Based on requirements of modern vehicles, in vehicle Control Area Network (CAN) architecture has been implemented. In order to reduce point to point wiring harness in vehicle automation, CAN is suggested as a means for data communication within the environment. The benefits of CAN bus based network over traditional point schemes will offer increased flexibility and expandability for future technology insertions. This project is aimed at the implementation of CAN protocol using PIC for vehicle monitoring system and security using Principle component analysis. The main feature of the system includes monitoring of various vehicles. In the security part, The system automatically takes photos of driver and compares his or her face with database to check whether he is an authenticated driver or not. He can have access to the vehicle only if he is an authenticated driver. If he is not an authenticated driver access to the vehicle will not be provided. Also, the owner of the vehicle gets an image of the theft via Email .Which is an additional feature of the given system.*

*Index Terms – Control Area Network, Principle Component Analysis, ARM Processor, PIC Microcontroller, GPS*

## I. INTRODUCTION

### A. Control Area Network

The Controller Area Network (CAN) is an attractive alternative in the automotive and automation industries due to its ease in use, low cost and provided reduction in wiring complexity. The priority based message scheduling used in CAN has a number of advantages, some of the most important being the efficient bandwidth utilization, flexibility, simple implementation and small overhead. CAN is a serial bus communications protocol developed by Bosch [3] (an electrical equipment manufacturer in Germany) in the early 1980s. Thereafter, CAN was standardized as ISO-11898 and ISO-11519, establishing itself as the standard protocol for in vehicle networking in the auto industry. By networking the electronics in vehicles with CAN, however, they could be controlled from a central point, the Engine Control Unit (ECU), thus increasing functionality, adding modularity, and making diagnostic processes more efficient. CAN offer an efficient communication protocol between sensors, actuators, controllers, and other nodes in real-time applications, and is known for its simplicity, reliability, and high performance [1].

## B. Biometrics

Is used in the process of authentication of a person by verifying or identifying that a user requesting a network resource is who he, she, or it claims to be, and vice versa. It uses the property that a human trait associated with a person itself like structure of finger, face details etc. By comparing the existing data with the incoming data we can verify the identity of a particular person [2]. There are many types of biometric system like fingerprint recognition, face detection and recognition, iris recognition etc., these traits are used for human identification in surveillance system, criminal identification. Advantages of using these traits for identification are that they cannot be forgotten or lost. These are unique features of a human being which is being used widely [3].

The Principal Component Analysis (PCA) is one of the most successful techniques that have been used in image recognition and compression. PCA is a statistical method under the broad title of factor analysis. The purpose of PCA is to reduce the large dimensionality of the data space (observed variables) to the smaller intrinsic dimensionality of feature space (independent variables), which are needed to describe the data economically. This is the case when there is a strong correlation between observed variables.

Here Control Area Network is used to monitor the vehicle critical parts like Temperature, fuel level, Air bag control. This paper also included security for Car system. If owner lost the key, in that time also owner of that car can access the key by sending predefined message to the microcontroller, then microcontroller receives that message and if that message is correct than microcontroller sends a predefined question to that particular number and microcontroller waits for the answer, once owner send an answer microcontroller compares that answer with the predefined answer. If it matches than microcontroller opens the driver side door automatically. So that owner can access his car. Once the driver of that car sat on the seat, microcontroller initiate the web cam, so that web cam captures the image of that driver, matlab compares that image with database images, once its matches microcontroller ignites the car engine automatically. If not that particular image send to the owner E-mail and controller send the current location using global positioning system.

## II. RELATED WORK

### A. Control Area Network

Douglas W. Gage (1995) discusses the history of developments made in control of unmanned ground vehicles. The basic idea of a digital driving system and how to formulate digital driving system architecture have been discussed by Wuhong Wang (2002), C. Little (1999), Gerd Krämer (2001), Fei-Yue Wang et al (2002), Julian Kolodko et al (2003). Luis Manuel et al (2002) and Richard Bishop (2000) have dealt with the various features that can be included to improve the driving experience in a digital driving system. Tatsuya Yoshida et al (2004) discuss the concept of adaptive driving systems. U. Franke et al (1999) discusses various approaches to develop autonomous vehicles. The issues in developing a CAN based embedded network system have been dealt by Robert Boys (2004), Steve Corrigan (2002) and John Rinaldi et al (2003). The website of Microchip Inc. USA gives information about how to develop a CAN system using their microcontroller PIC 18F4685. The website of CAN in Automation (CiA) provides information about the basics of CAN protocol.

### B. Face Recognition

According to Jolliffe (2002) it is generally accepted that PCA was first described by Karl Pearson in 1901. In his article "On lines and planes of closest fit to systems of points in space," Pearson (1901) discusses the graphical representation of data and lines that best represent the data. He concludes that "The best-fitting straight line to a system of points coincides in direction with the maximum axis of the correlation ellipsoid". He also states that the analysis used in his paper can be applied to multiple variables. However, PCA was not widely used until the development of computers. It is not really feasible to do PCA by hand when number of variables is greater than four, but it is exactly for larger amount of variables that PCA is really useful, so the full potential of PCA could not be used until after the spreading of computers (Jolliffe, 2002). According to Jolliffe (2002) significant contributions to the development of PCA were made by Hotelling (1933) and Girshick (1936; 1939) before the expansion in the interest towards PCA. In 1960s. as the interest in PCA rose, important contributors were Anderson (1963) with a theoretical discussion, Rao (1964) with numerous new ideas concerning uses, interpretations and extensions of PCA, Gower (1966) with discussion about links between PCA and other statistical techniques and Jeffers (1967) with a practical application in two case studies.

### C. Traditional techniques

#### i. Geometric approach

This is the historical way to recognize people. Geometric features may be generated by segments, perimeters and areas of some figures formed by the points. The featured set is studied to compare the recognition result. Distances in the feature space from a template image to every image in the database were calculated. Following to the FERET protocol, 5

nearest face images were derived and if there were photos of the query person then the result was considered positive. Each image was tested as a query and compared with others. The approach was robust, but its main problem is automatic point location. Some problem arises if image is of bad quality or several points are covered by hair.

#### ii. *Photometric approach*

It is a statistical approach that distills an image into values and compares the values with templates to eliminate variances. It relies on the input image in the presence of light and the geometric location of different angles. The photometric transformation is implemented on the source image, does not take into account photometric changes, i.e. changes in the pixel. The main restriction in this approach is that multiple registered images of the same person is required. Since it recognizes the new image by checking that it is spanned in a linear subspace of the multiple gallery images, it cannot handle the new images of a different person which is not included in the gallery set[4].

### III. HARDWARE

Fig 1 shows the vehicle monitoring system, sensors are connected to each node. Microcontroller receives the data from the sensors and data exchange is also possible. If node 3 wants data from the node 1, node 3 has to send a remote request to the node 1, so that node 1 will transmit the sensor value to the requested frame. So that by sending the remote request continuously node 3 will monitor the various nodes in the system.

Fig 2 shows the security system, whenever an owner lost his key, he can access his vehicle by sending a predefined message to the security system. GSM receives the message, and controller compares that message with predefined text, if it matches controller sends a pre-defined question to an owner cell, then owner has to send answer to that question. Then GSM receives the answer and send that to controller, once again controller compares that text with predefined, if it matches controller automatically opens the driver side door.

Then monitoring system continuously monitoring the seat belt of the driver seat, if metal sensor senses monitoring system sends a signal to the security system. Then security system initiates the web cam, webcam captures the image of the driver, using Principle Component Analysis technique compares the captured image with data base stored images, if image matches with those data base images security part ignites the engine, if not security part sends that captured image to the owner Email id and it will also send the location information

#### A. *LDR Sensor*

A photo resistor or light-dependent resistor (LDR) is a light-controlled variable resistor. The resistance of a photo resistor decreases with increasing incident light intensity in other words, it exhibits photoconductivity. A photo resistor can be applied in light-sensitive detector circuits, and light- and dark-activated switching circuits. A photo resistor is made of a high resistance semiconductor. In the dark, a photo resistor can have a resistance as high as a few mega ohms (M $\Omega$ ), while in the light, a photo resistor can have a resistance as low as a few hundred ohms. If incident light on photo resistor exceeds a certain frequency, photons absorbed by the semiconductor give bound electrons enough energy to jump into the conduction band. The resulting free electrons (and their hole partners) conduct electricity, thereby lowering resistance. The resistance range and sensitivity of a photo resistor can substantially differ among dissimilar devices. Moreover, unique photo resistors may react substantially differently to photons within certain wavelength bands.

#### B. *Glass Breakage Sensor*

Glass break detectors usually use a microphone, which monitors any noise or vibrations coming from the glass. If the vibrations exceed a certain threshold (that is sometimes user selectable) they are analysed by detector circuitry. Simpler detectors simply use narrowband microphones tuned to frequencies typical of glass shattering, and react to sound above certain threshold, whereas more complex designs compare the sound analysis to one or more glass-break profiles using signal transforms similar to DCT and FFT and react if both the amplitude threshold and statistically expressed similarity threshold are breached.

#### C. *Distance Sensor*

A proximity sensor is a sensor able to detect the presence of nearby objects without any physical contact. A proximity sensor often emits an electromagnetic field or a beam of electromagnetic radiation (infrared, for instance), and looks for changes in the field or return signal. The object being sensed is often referred to as the proximity sensor's target. Different proximity sensor targets demand different sensors.

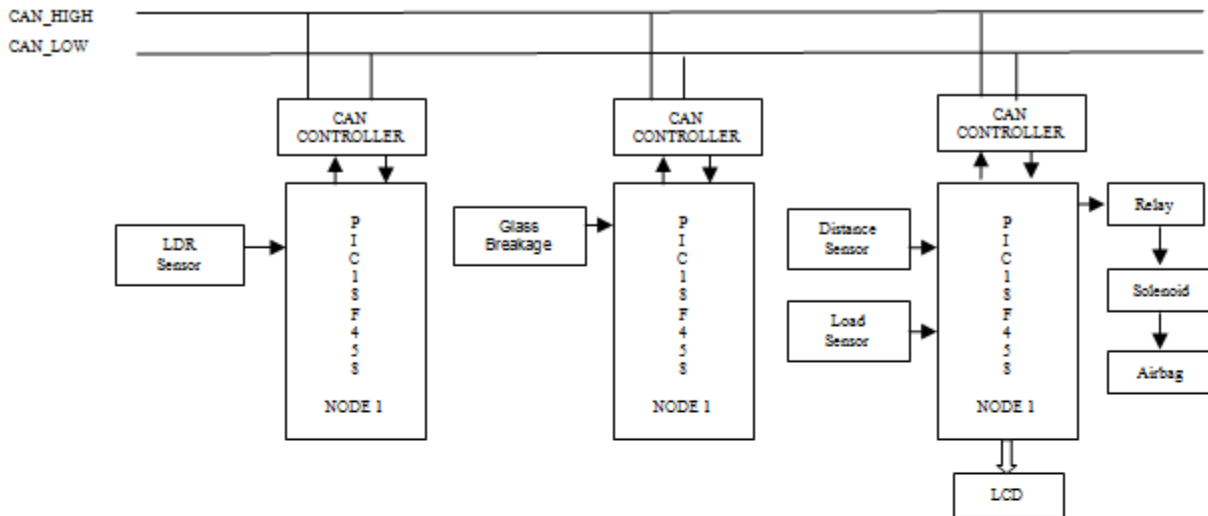

Fig. 1 Monitoring System

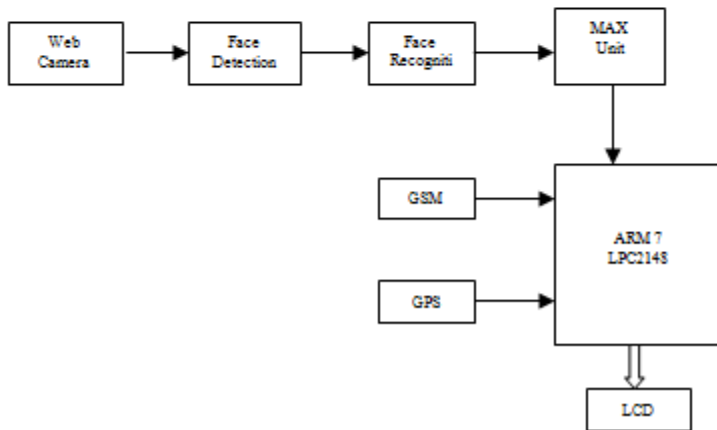

Fig. 2 Security System

For example, a capacitive or photoelectric sensor might be suitable for a plastic target; an inductive proximity sensor always requires a metal target.

#### D. Load Sensor

A load cell is a transducer that is used to convert a force into an electrical signal. This conversion is indirect and happens in two stages. Through a mechanical arrangement, the force being sensed deforms a strain gauge. The strain gauge measures the deformation (strain) as an electrical signal, because the strain changes the effective electrical resistance of the wire. A load cell usually consists of four strain gauges in a Wheatstone bridge configuration. Load cells of one strain gauge (Quarter Bridge) or two strain gauges (half bridge) are also available. The electrical signal output is typically in the order of a few mill volts and requires amplification by an instrumentation amplifier before it can be used. The output of the transducer can be scaled to calculate the force applied to the transducer.

### IV. PROPOSED TECHNIQUE

There are several techniques behind face recognition; we would be focusing on real time application of Principal Component Analysis using Eigen faces. In this method the difference between a given face image and a mean image is weighted, which is obtained by averaging a predefined set of faces. The training set is a group of face images from which the mean face is calculated. Face recognition takes place by linearly projecting the image to a low dimensional image space and weighting the difference with respect to a set of eigenvectors. If the difference (weight) is below certain threshold, the image is recognized as a known face; otherwise, the face can be classified as an unknown face or not a face at all. This is done with

the help of mat lab code initializing the webcam of a laptop, capturing the image and comparing it with the database of images (training images) present in the laptop.

Perform face recognition, the similarity score is calculated between an input face image and each of the training images. The matched face is the one with the highest similarity, and the magnitude of the similarity score indicates the confidence of the match (with a unit value indicating an exact match). There are various steps in performing this face recognition, we will be discussing step by step, however before that we will be discussing about Eigen faces used in this paper.

The Eigen faces approach for face recognition involves the following two operations:

*A. Initialization process*

The steps involve in initialization process are

- Acquire a set of training images.
- Calculate the Eigen faces from the training set, keeping only the best *M* images with the highest Eigen values. These *M* images define the “face space”. As new faces are experienced, the Eigen faces can be updated.
- Calculate the corresponding distribution in *M*-dimensional weight space for each known individual (training image), by projecting their face images onto the face.

*B. Recognition process*

Having initialized the system, next process involves is recognition process and the steps involves in this process are,

- Given an image to be recognized, calculate a set of weights of the *M* Eigen faces by projecting the it onto each of the Eigen faces.
- Determine if the image is a face at all by checking to see if the image is sufficiently close to the face space.
- If it is a face, classify the weight pattern as either a known person or as unknown.
- (Optional) Update the Eigen faces and/or weight patterns.
- (Optional) Calculate the characteristic weight pattern of the new face image, and incorporate into the known faces.

V. IMPLEMENTATION

*A. Acquire a set of training images*

Training set of *m* images of size *N* x *N* are represented by vectors of size *N*<sup>2</sup>. Each face is represented by  $\Gamma_1, \Gamma_2, \Gamma_3 \dots \Gamma_M$ . Feature vector of a face is stored in a *N* x *N* matrix. Now, this two dimensional vector is changed to one dimensional vector. For example,

$$\begin{bmatrix} x1 & x2 \\ x3 & x4 \end{bmatrix} = \Gamma_i = \begin{bmatrix} x1 \\ x2 \\ x3 \\ x4 \end{bmatrix}$$

Each face image is represented by the vector  $\Gamma_i$ .

*B. Mean and Mean Centred Images*

Average face image is calculated by,

$$\Psi = (1/M) \sum_{i=1}^M \Gamma_i$$

$$\Psi = (\Gamma_1 + \Gamma_1 + \Gamma_1 + \dots + \Gamma_M) / M.$$

Each face differs from the average by  $\Phi_i = \Gamma_i - \Psi$  which is called mean cantered image.

*C. Covariance Matrix*

A covariance matrix is constructed as  $C = A A^T$ , where  $A = [\Phi_1, \Phi_1, \Phi_2 \dots \Phi_M]$  of size *N*<sup>2</sup>x *N*<sup>2</sup>. Size of covariance matrix will be *N*<sup>2</sup> x *N*<sup>2</sup>. Eigen vectors corresponding to this covariance matrix is needed to be calculated, but that will be a tedious task therefore, calculate  $A^T A$  Size of this matrix *M* x *M*. Then calculate the Eigen vector and Eigen value of the covariance matrix of size *M* x *M*.

Consider the eigenvectors  $v_i$  of  $A^T A$  such that,

$$A^T A X_i = \lambda_i X_i$$

Now multiplying the above equation with A both sides we get,

$$AA^T (AX_i) = \lambda_i(AX_i)$$

#### D. Eigen Face Space

The Eigen vectors of the covariance matrix  $AA^T$  are  $AX_i$  which is denoted by  $U_i$ .  $U_i$  resembles facial images which look ghostly and are called Eigen faces. Eigen vectors correspond to each Eigen face in the face space and discard the faces for which Eigen values are zero thus reducing the Eigen face space to an extent. The Eigen faces are ranked according to their usefulness in characterizing the variation among the images.

A face image can be projected into this face space by,

$$k = U^T (\Gamma_k - \Psi)$$

$k = 1, \dots, M$ , where  $(\Gamma_k - \Psi)$  is the mean centered image.

Hence projection of each image can be obtained as  $\Omega_1$  for projection of image  $\Omega_1$  and  $\Omega_2$  for projection of image  $\Omega_2$  and hence forth.

#### E. Recognition Step

The test image,  $\Gamma$ , is projected into the face space to obtain a vector,  $\Omega$  as

$$\Omega = U^T (\Gamma - \Psi)$$

The distance of  $\Omega$  to each face is called Euclidean distance and defined by

$$\epsilon_k^2 = \|\Omega - \Omega_k\|^2$$

Where  $k = 1, \dots, M$  where  $\Omega_k$  is a vector describing the  $k^{\text{th}}$  face class.

A face is classified as belonging to class  $k$  when the minimum  $\epsilon_k$  is below some Chosen threshold  $\theta_c$ . otherwise the face is classified as unknown.  $\theta_c$ , is half the largest distance between any two face images:

$$\theta_c = (1/2)\max_{j,k} \|\Omega_j - \Omega_k\|$$

where  $j, k = 1, \dots, M$

Find the distance  $\epsilon$  between the original test image  $\Gamma$  and its re-constructed image from the Eigen face  $\Gamma_f$

$$\epsilon^2 = \|\Gamma - \Gamma_f\|^2$$

Where  $\Gamma_f = U * \Omega + \Psi$ .

If  $\epsilon \geq \theta_c$  then input image is not even a face image and not recognized.

If  $\epsilon < \theta_c$  and  $\epsilon_k > \theta$  for all  $k$  then input image is a face image but it is recognized as unknown face.

If  $\epsilon < \theta_c$  and  $\epsilon_k > \theta$  for all  $k$  then input images are the individual face image associated with the class vector  $\Omega_k$ [5].

## VI. RESULTS AND CONCLUSIONS

This thesis is concerned about implementation of CAN nodes for monitoring parameters and security for car systems. The monitoring parameters are temperature, battery voltage, light due to spark or fire and CO level in the exhaust. For monitoring the above parameters, LM35 sensor, LDR and MQ6 sensors are used. For implementing this, the programming of LED, ADC and LCD interfacing with microcontroller is done using Embedded C. In this project, the real time face recognition is achieved using PCA algorithm. An embedded automotive security system is presented in this paper. Face recognition is a both challenging and important recognition technique. It has been shown that a proposed system can be implemented at any types of automobiles and can be used at any place where face recognition is needed. This system reduces increased amount of vehicle theft present today. Comparing with traditional automotive system, this system does not need any sensor, and thus it is highly reliable.

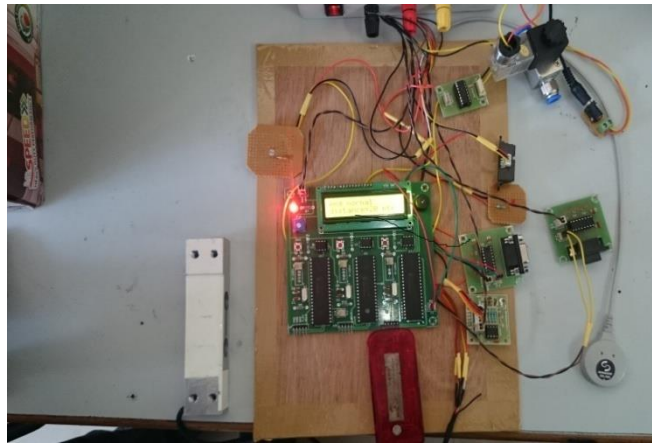

Fig. 3 Schematic of Monitoring System

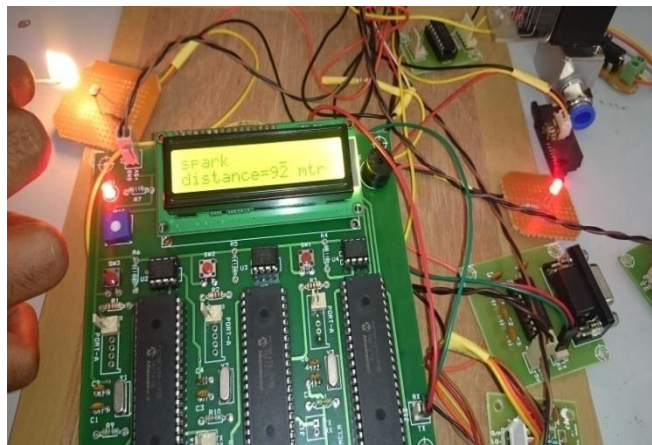

Fig. 4 Monitoring System

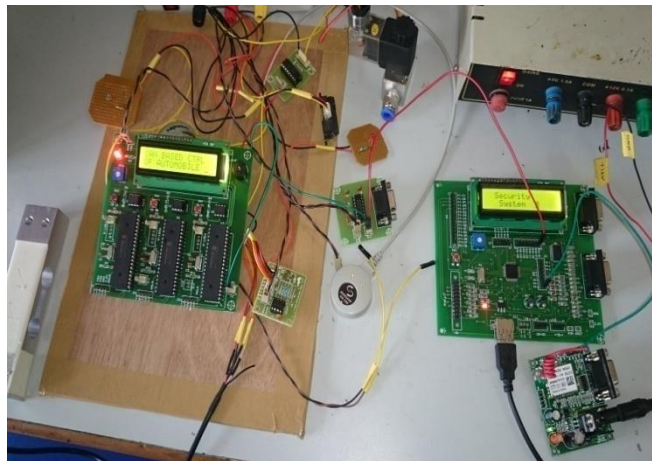

Fig. 5 schematic of overall system

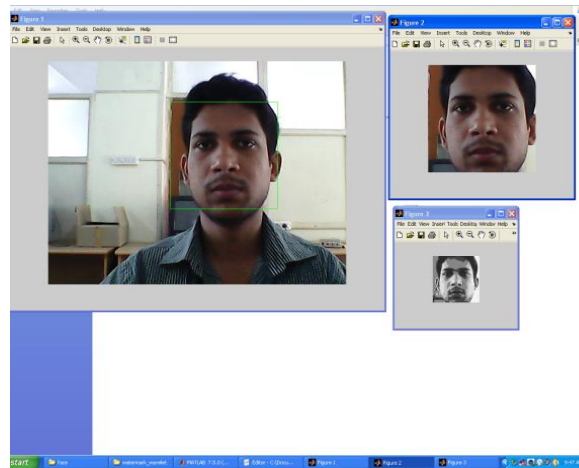

Fig. 6 Unknown image



Fig. 7 Unknown image image result



Fig. 8 known image



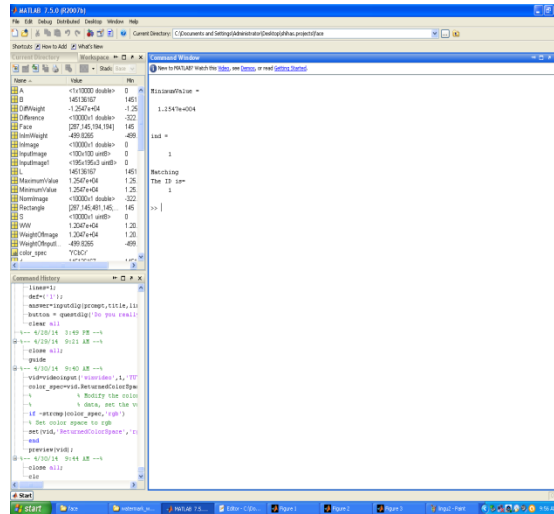

Fig. 7 known image image result

### REFERENCES

- [1] Karl Henrik Johansson, Martin Torngren, and Lars Nielsen, "Vehicle Application of Controller Area Network". *proc of The Handbook of Networked and Embedded Control Systems Control Engineering*, vol.-4, pp.741-76, 2005
- [2] Anil K.Jain, Robert P.W. Duin, and Jianchang Mao. "Statistical Pattern Recognition: A Review". *IEEE Transactions on Pattern Analysis and Machine Intelligence*, vol. -22, no.1, pp. 4 - 37, January 2000.
- [3] Sunita Kumari, Pankaj K.Sa, and Banshidhar Majhi. "Gender classification by principal component analysis and support vector machine". In *ACM International Conference on Communication, Computing & Security, ICCCS 2011*, pp. 339 - 342, Rourkela, India, February 2011.
- [4] Kandla Arora, "Real Time Application of Face Recognition Concept", *International Journal of soft computing and Engineering (IJSCE)*, ISSN: 2231-2307, volume-2, Issue-5, November 2012.