

International Journal of Computer Science and Mobile Computing



A Monthly Journal of Computer Science and Information Technology

ISSN 2320-088X

IJCSMC, Vol. 3, Issue. 9, September 2014, pg.01 – 09

RESEARCH ARTICLE

Designing of Microstrip Feed Antenna by Combining Circular and Square Microstrip Antennas

Manish Kumar¹, Kapil Kumawat², Sarita Gajraj³

^{1,2,3}Department of Electronic and Communication (SBCET, Jaipur RTU KOTA), INDIA

Email: ¹ manish4740@gmail.com, ² kapilkumawat@gmail.com, ³ sarita.gajraj@jnit.org

Abstract- This paper presents a designing of microstrip patch antenna immixing circular and square slots by cutting different slots on rectangular microstrip patch antenna and experimentally studied on IE3D software. This design is achieved by cutting poly shapes in square pattern combining with circular and square slots & placing a microstrip line feed. This design has been studied in iterations III. The radiation pattern of the aimed microstrip antennas maintained because of the self-similarity and centro-symmetry of the fractal shapes. With fractal shapes microstrip patch antenna is designed on a FR4 substrate of relative permittivity of 4.4 and thickness 1.524mm and mounted above the ground plane at a height of 6 mm. Details of the measured and pretend results of the case-by-case iterations are presented & discussed.

Keywords – Microstrip antenna, Radiation pattern, Returns loss

I. INTRODUCTION

In communication system there are a variety of microstrip antennas the majority common of which is microstrip patch antenna.[12] A patch antenna is a narrow band, wide-beam antenna fabricated by print the antenna element pattern in metal trace bonded to an insulating dielectric substrate. A microstrip (patch) antenna is a kind of radio antenna which can be mounted on plane surface. It consists of a flatbed rectangular sheet of metal, mounted over a larger sheet of metal called a ground plane. A patch antenna is usually constructed on a dielectric substrate using the same materials & lithography processes used to make printed circuit boards. Microstrip antennas [6] are becoming more and more useful because they can be printed directly onto a circuit board. These antennas are also becoming very permeative within the mobile phone market.[1] Microstrip antennas are cheap, low profile & simply fabricated. These are relatively low-priced to manufacture & design because of the simple 2-dimensional physical geometry. These are also light weight, conformal shaped, able of dual & triple frequency operations. These are very efficient, easily integrated to circuits, easy to planer & non-planer surfaces and are compatible with MMIC design. These all features make patch antennas widely implemented in numerous applications, such as high

performance aircrafts, wireless communication, missile and satellite applications. However microstrip antennas have disadvantages also, narrow bandwidth being a serious limitation. Different methods are projected to improve it, and one of the methods proposed by various researchers is by cutting slots on it. In this paper we have designed a Microstrip Patch antenna using proposed by various researchers is by cutting slots on it. In this paper we have designed a microstrip feed antenna by combining circular and square microstrip antennas.

The purpose of this work is to design a microstrip patch antenna using viable simulation software. IE3D, from zeland software, Inc., [7] is an electromagnetic simulation and optimization software useful for circuit and antenna design. IE3D has a menu driven graphic interface for model generation, and uses a field solver based on full wave, method-of-moments to solve current distribution on 3D and multi-layer structures of general shape.

II. FRACTAL SLOTS

Fractals mean asymmetrical fragments. Fractals describe a composite set of geometries ranging from self similar/ self-affine to other irregular structure. Fractals are generally composed of various copies of themselves at different scales and hence do not have a predefined size, which makes their use in antenna design very capable. Fractal antenna engineering is an issuing field that employs fractal concepts for developing new types of antennas with prominent characteristics. Fractal shaped antennas show some attractive features which results from their geometrical properties [8]. The inimitable features of fractals such as self-similarity and space filling properties enable the realization of antennas with interesting feature such as multi-band operation and miniaturization. A self-sowed set is one that consists of scaled down copies of itself. This property of self-similarity of the irregular fragment geometry [11] aids in the design of fractal antennas with multiband feature. The self-sown current distribution on these antennas is expected to cause its multiband characteristics. The space-filling characteristics of fractals tend to fill the area occupied by the antenna as the order of iteration is increased. Higher order fractal antennas feat the space-filling property and enable miniaturization of antennas. Fractal antennas and arrays also display lower side-lobe levels. Fractals have been applied successfully for miniaturization and multi-band operations of simple antennas generally dipole, loops and patch antennas. It has been observed that such as approach result in decrease of the input impedance bandwidth [9].

III. MICROSTRIP LINE FEED

In microstrip line feed technique, a conducting strip is connected directly to the edge of the microstrip patch as shown in the figure below.

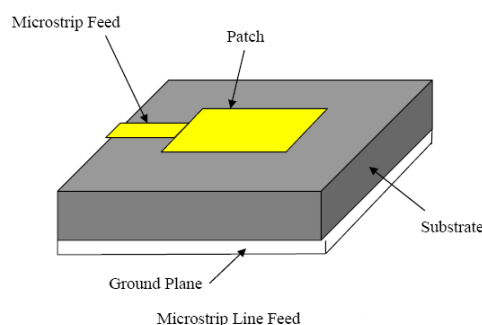

Figure 1: Microstrip line feed

The conducting strip is smaller in width as compared to the patch & this kind of feed arrangement has the gain that the feed can be imprinted on the same substrate to provide a planar structure. The purpose of the inset cut in the patch is to match the impedance of the feed line to the patch without the need for any additional matching element. This is achieved by properly

controlling the inset position. Hence this is a trouble-free feeding scheme, since it provides ease of fabrication & simplicity in modeling as well as impedance matching. However as the thickness of the dielectric substrate being used, increases surface waves & fake feed radiation also increases, which hampers the bandwidth of the antenna. The feed radiation also leads to undesired cross polarized radiation.[2]

IV. ANTENNA DESIGN

The design idea was taken from broadband antennas to make the antenna work in a large band of frequencies of the many broadband antennas, square and circular patch antenna was chosen. Hence the chosen shape of the patch was cutting of different square slots in iteration I, different circular slots[13] in iteration II and designs of both iteration I, and iteration II are collective to get resultant geometry of iteration III ,with an aim to achieve smaller size antenna[4]. The software used to model and simulate the microstrip patch Antenna using circular and square slots was IE3D, it can be used to calculate and plot VSWR, return loss, radiation pattern, smith chart and various other parameters.

ITERATION I

The geometry of iteration I of proposed microstrip patch antenna using Rectangular slots presented in fig.2 with front (top) view.

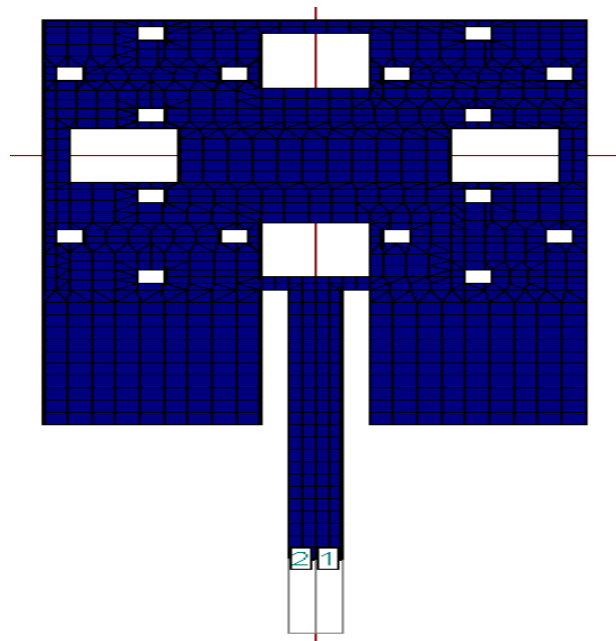

Figure 2. Geometry of iteration 1 with $t=1.524$, Permittivity=4.4 and grid size=.025 , $l=20$, $w=20$, feed length=20mm, feed width=2mm. big square= $4*4$,small square=1mm.

The drawing of iteration I is achieved by cutting square slots on a rectangular microstrip antenna. In the centre one square slot is taken and 4 square fractal slots are taken on each corner of the central slot. The dimension of the central square fractal slot is 4-4(length-width) and the dimensions of each of the four corner fractal slots are 1-1(length-width).

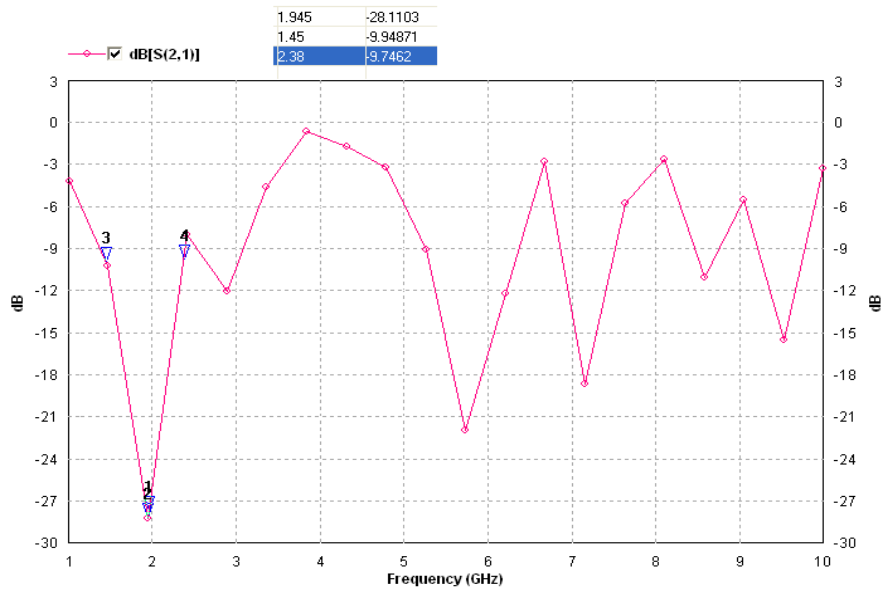

Figure 3. Return loss vs. Frequency curve of iteration I for proposed antenna

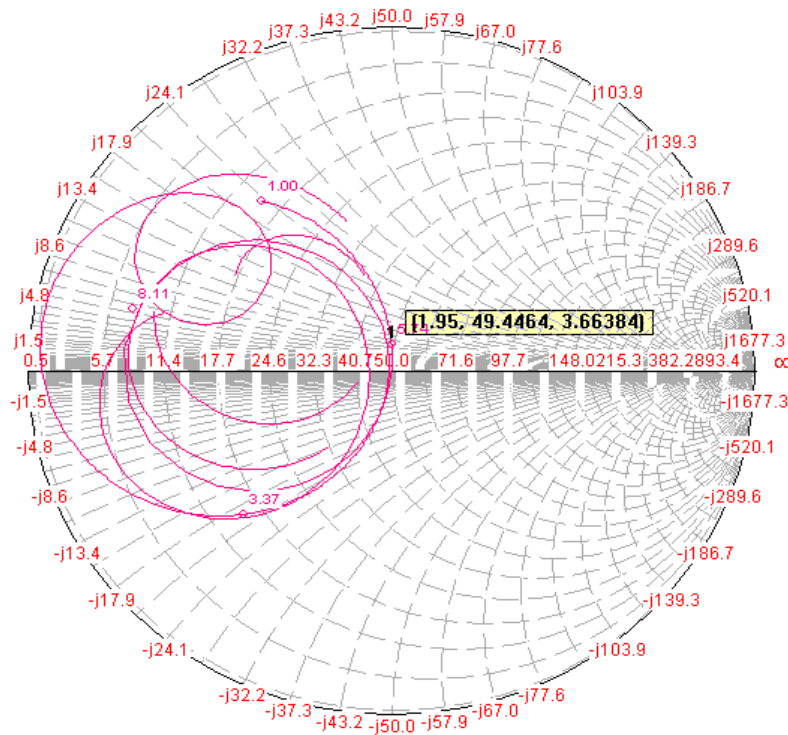

Figure 4. Input impedance loci using smith chart of iteration I

ITERATION II

The design of iteration II of proposed microstrip patch antenna using circle slots shown in fig.5 with front (top) view.. In this drawing four circular slots are taken on each corner of the rectangular microstrip antenna. The radius of four circle slots are 2mm(6,6) . In the center one crown circle slot taken. Radius of this circle is 4mm(0,0).

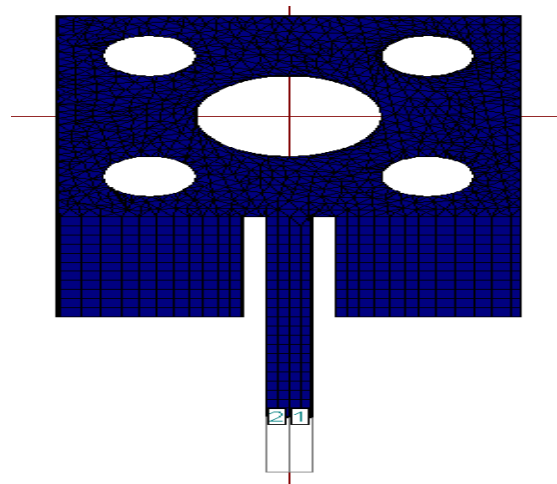

Figure 5. Geometry of iteration II for proposed antenna. Big circle=4mm(0,0),small circle=2mm,radius(6,6)

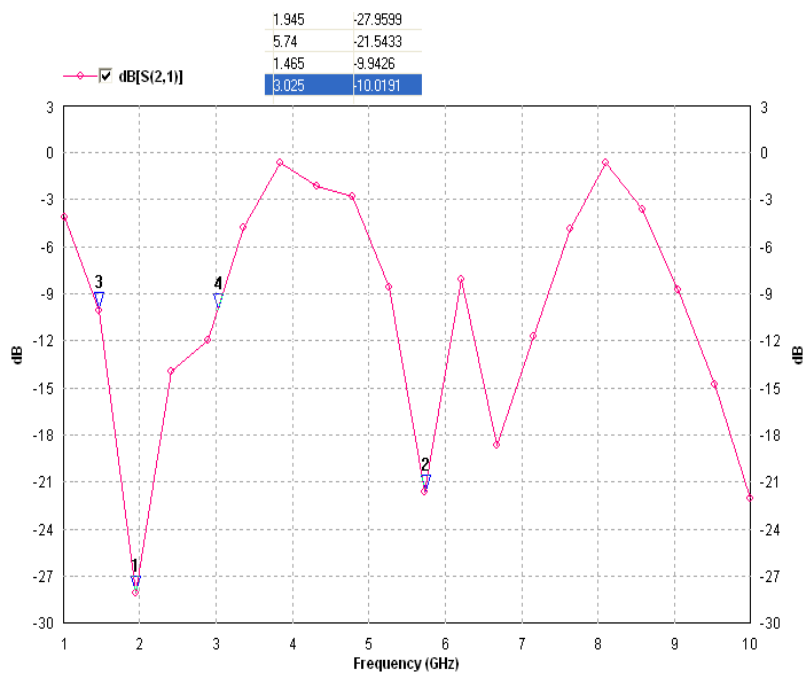

Figure 6. Return loss vs. Frequency curve of iteration I for proposed antenna

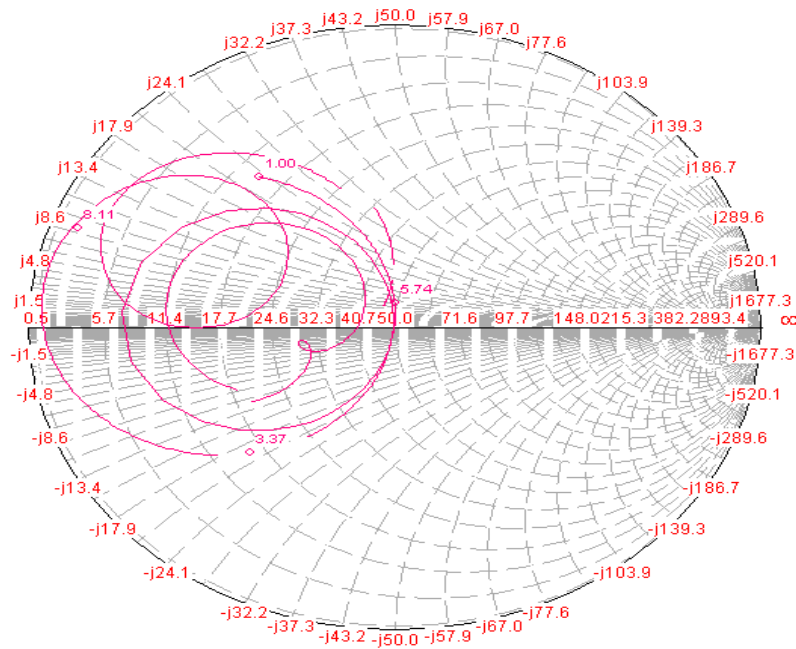

Figure 7. Input impedance loci using smith chart of iteration II

ITERATION III

The drawing of iteration III of proposed microstrip patch antenna using circular and square feed presented in fig.8 with front (top) view.

Resultant geometry of iteration III is obtained by combining the geometry of both iterations I & II. This is done so that better result can be achieved with Iteration III in comparison to the individual iterations.

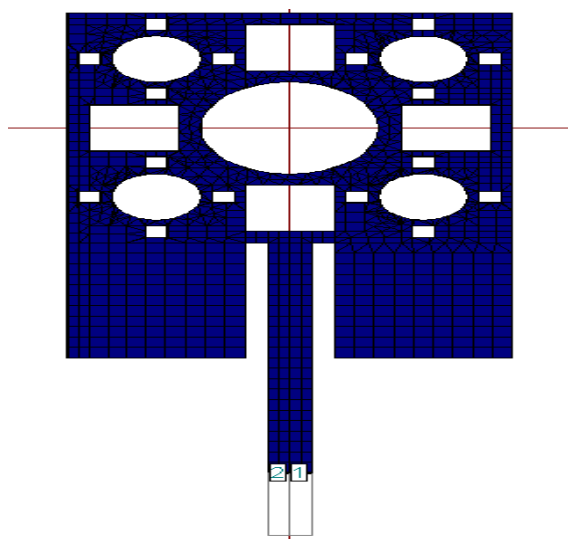

Figure 8. Geometry of iteration III for proposed antenna. Big square=4*4mm (7,0),small square=1*1mm(6,9)

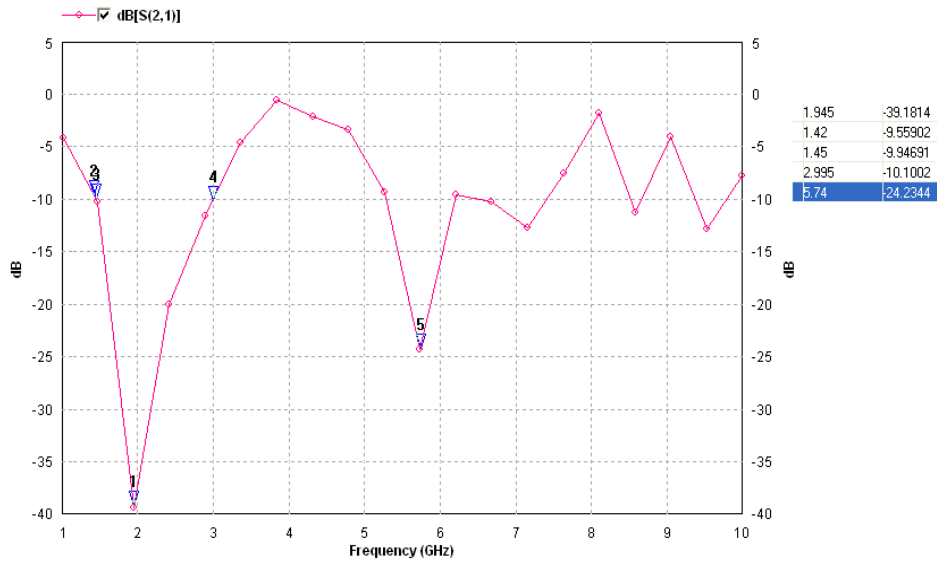

Figure 9. Return loss vs. frequency of iteration III for proposed antenna

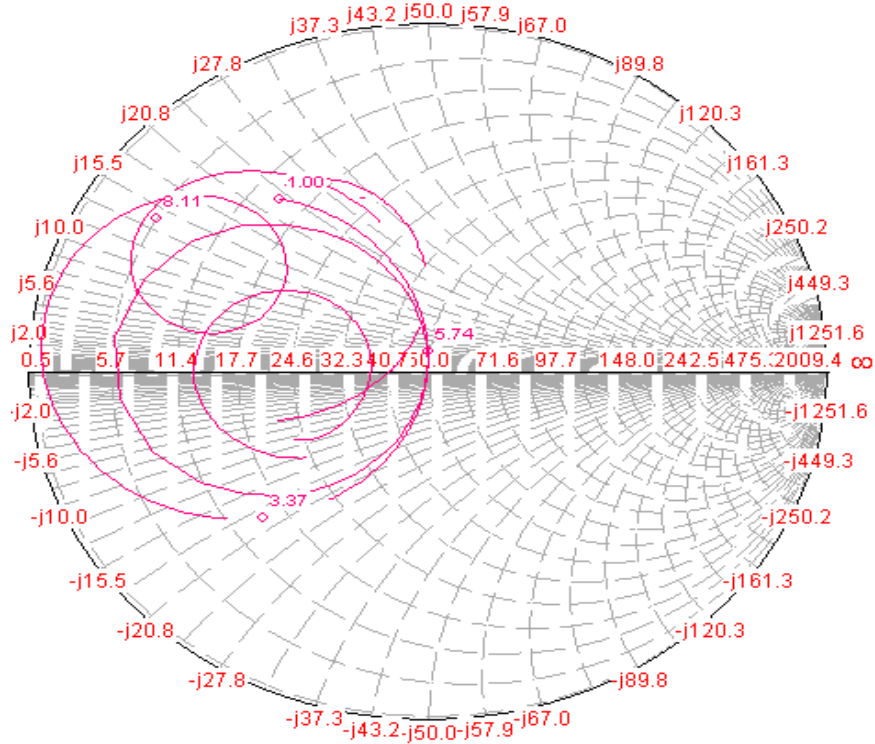

Figure 10. Input impedance loci using smith chart for iteration III

Table1: Comparison of different results of Iteration I, II & III

Types	Iteration I	Iteration II	Iteration III
Resonant Frequency	1.945	1.945	1.945
VSWR	1.08	1.06	1.02
Return Loss	-28.113	-27.995	-39.1814
Bandwidth	47%	80%	80%

These results from the table1 show that the mixture of Iterations I & II, Iteration III produced enhanced results than the individual iterations. The results for VSWR & Return loss for Iteration III have improved compared to Iteration I & II. Also the bandwidth of Iteration III. These results are in line with the objective of this paper.

V. RESULTS AND DISCUSSION

The expected antenna has been simulated by using IE3D by Zealand Software Inc.[7] .It is considered as a point of reference for electromagnetic simulation packages. The principal formulation of the IE3D is an integral equation obtained through the use of Green's functions. In the IE3D, it is possible to model both the electric current on a metallic structure & a magnetic current instead of the field distribution on a metallic aperture

In this paper, square microstrip patch antenna circular and square feed slots is made-up on a FR4 substrate of thickness 1.524 mm and relative permittivity of 4.4. It is mounted above the ground plane at height of 6 mm.[5]

Table 1 shows the variation of return loss with frequency, VSWR and Bandwidth for iteration I, II and III. Plot result shows resonant frequency 1.945 GHz. Minimum return loss for iteration I and II is -28.113 and -27.995 respectively .Minimum -39.1814db return loss is available at resonant frequency for iteration III which is significant. Fig.4, 7 and 10 shows the input impedance loci using smith chart for iteration I, II and III respectively. In each iteration Input impedance curve passing near to the 1 unit impedance circle that shows the perfect matching of input. And total available impedance bandwidth is 47% for iteration I, 80% for iteration II and 80% for iteration III.[3]

VI. CONCLUSION

Traditional wideband antennas (spiral and log-periodic) and arrays [10] can be analyzed with fractal geometry to shed new light on their operating principles. More to the point, a number of new configurations can be used as antenna elements with good multiband characteristics. Due to the space filling properties of fractals, antennas designed from certain fractal shapes can have far better electrical to physical size ratios than antennas designed from an understanding of shapes in Euclidean space.

The measurement results show a maximum patch size reduction is achieved by the proposed fractal antennas, without debasing the antenna performances, such as the return loss and radiation patterns. The essence of this size reduction technique is loading the inductive elements along the patch edges, and loading Self-sown slots inside the patch, to increase the length of the current path. The essence of the maintenance of the antenna radiation patterns is the self-similarities and centro symmetry of the fractal shapes[9]. The main reward of the proposed method are: (i) great size reduction achieved , (ii) the radiation patterns maintained, (iii) wider operating frequency bandwidth achieved, (iv) no vias to the ground, and (v) easiness of the design methodology. To the best of our facts, this is the most effective technique pro- posed for the miniaturization of

microstrip patch antennas so far. The small-size patches derived from this technique can be used in integrated low-profile wireless communication systems successfully. With the aim to continue compactness requirements and to maintain the overall layout as simply as possible and keeping the realization cost very low.

REFERENCES

- [1] James, J.R. and Hall, P.S.: 'Handbook of Microstrip Antennas' (Peter Peregrinus)
- [2] Constantine A. Balanis: 'Antenna Theory, Analysis and Design' (John Wiley & Sons)
- [3] Bhomia Y.,Chaturvedi A., Yadav D., "Truncated Tip Triangular Microstrip Patch Antenna", Proc. IEEE. Int Symp. Antenna Propag.,vol. 2, pp. 212 -214, 2010.
- [4] Kai-Fong Lee, Kwai- Man Luk, Jashwant S. Dahele, 'Characteristics of the Equilateral Triangular Patch Antenna ' IEEE Tran. Antennas Propag.1988;36;1510.
- [5] C. L. Mak, K. M. Luk, K. F. Lee, ' Wideband Triangular Patch Antenna' IEE. Proc. Microwave Antennas Propag. 1999.
- [6] I. J. Bahl and P. Bhartia, 'Microstrip Antennas, Artech House, Dedham, MA, 1980.
- [7] IE3D [1] by Zeland software Inc.
- [8] H. O. Peitgen, H. jurgens, and D. Saupe, Chaos and Fractals. New York: Springer-Verlag, 1990.
- [9] M. F. Barnsley, R. L. Devaney, B. B. Mandelbrot, H. O. Peitgen, D.Saupe, R. F. Voss, Y. Fisher, and M. Mc Guire, The Science of Fractal Images. New York: Springer-Verlag, 1988.
- [10] Yogesh Bhomia et.al., "V-Slotted Triangular Microstrip Patch Antenna", Int. Journal of Electronics Engineering, vol. 2,no.1, pp. 21- 23,2010
- [11] K. J. Vinoy, J. K. Abraham, and V. K. Varadan, "On the Relationship Between Fractal Dimension and the Performance of Multi-Resonant Dipole Antennas using Koch Curves," IEEE Transactions on Antennas and Propagation, AP-5 1, 9,2003,pp.2296-2303.
- [12] Bhomia, Y., A. Kajla, and D. Yadav, "Slotted right angle triangular microstrip patch antenna," International Journal of Electronic Engineering Research, Vol. 2, No. 3, 393-398, 2010.
- [13] Bhomia Y.,Chaturvedi A., Yadav D.," Microstrip Patch Antenna Combining Crown and Sierpinski Fractal-Shapes ", Proc. IEEE. Int Symp. Antenna Propag.,vol. 2, pp. 212 -214, 2010